

TZ1030

Ultra Low Power Smart Sensor interface and Transceiver Platform

Description

The Sensium™ TZ1030 is an ultra low power wireless sensor interface platform for a wide range of applications in healthcare, sports and lifestyle management. The device includes an RF transceiver, digital block with 8051 processor and a reconfigurable sensor interface. On-chip program and data memory permits local processing of signals. This capability can significantly reduce the transmit data payload.

The Sensium™ together with appropriate external sensor(s) provides ultra low power monitoring of temperature, ECG, physical activity, blood glucose and oxygen levels. It can also interface to 3 axis accelerometers, pressure sensors and monitor temperature on chip or using an external sensor.

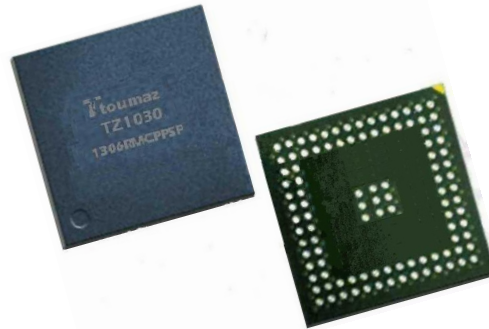

TZ1030 chip

Features

- 1.0–1.5Volt (zinc air battery compatible)
- >1yr operation on 30mAh battery possible
- Ext/internal temperature sensor interface
- Single lead ECG interface
- 3 axis accelerometer interface
- Amperometric/Isfet sensor interfaces
- 8051 Processor free for customer apps
- Package 121 WFSGA 6x6x0.8mm

Applications

- Temperature monitoring
- ECG/heart rate monitoring
- Physical activity monitoring
- Home, hospital and ICU monitoring
- Diabetes/blood glucose monitoring.
- Personalised healthcare
- Treatment compliance
- Professional sports monitoring

Block Diagram of TZ1030

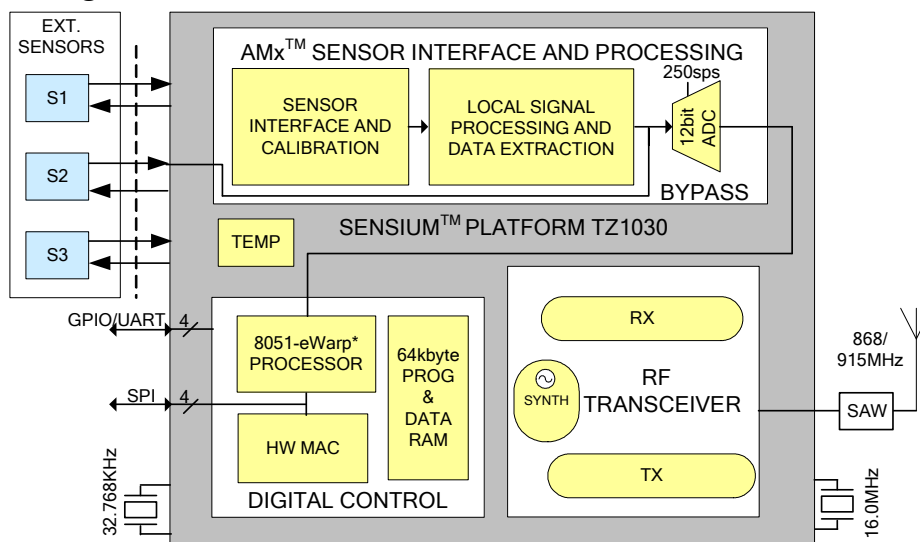

* © Mentor Graphics Corp, All rights reserved

ADVANCE PRODUCT INFORMATION V3_0

This device has not been approved for life-support devices or systems. Life-support devices or systems are intended to support and/or maintain and sustain and/or protect human life. If they fail, it is reasonable to assume that the health of the user or other persons may be endangered.

The application focus of the Sensium™ is sensor data collection, intelligent local processing and wireless transmission of vital signs and other health status information. For such an application, the system architecture can be split into three units as illustrated in Figure 1.

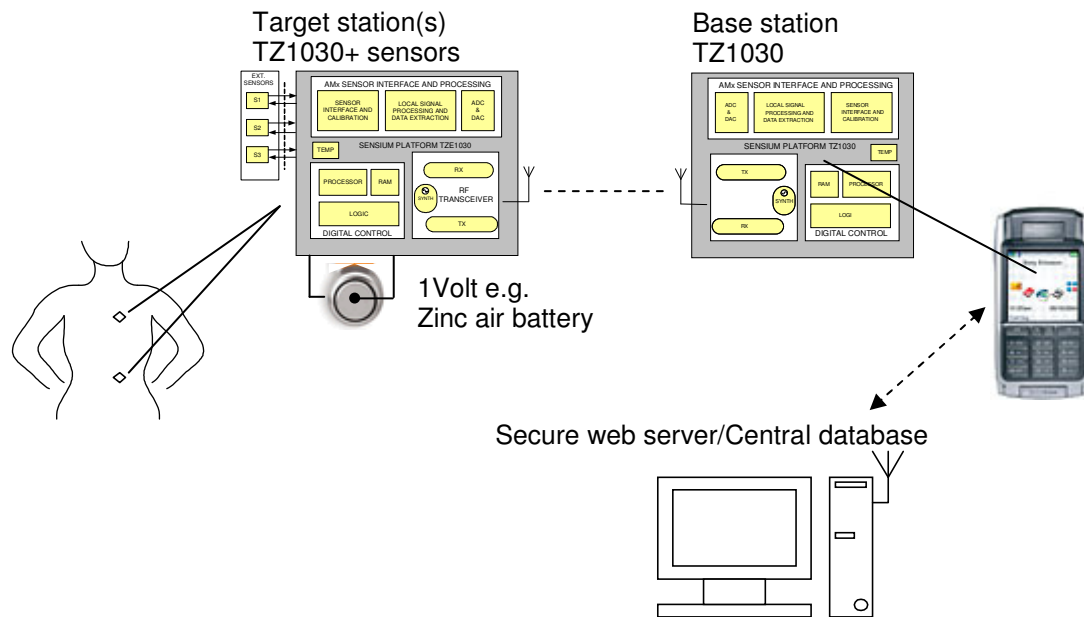

Figure 1 System Architecture for Wireless Body Monitoring

Wearable sensor nodes (target stations) support a range of sensors generating data at rates up to 50kbps. Very low level analog signals from the sensors are pre-processed by micro power circuitry (amplification, filtering, data conversion, data compression, modulation etc.) before being transmitted as an RF signal. This low power RF signal is then transmitted to the basestation. The basestation can be linked to up to 8 target stations, each monitoring multiple physiological signals on the body.

Table 1: Preliminary Sensium™ Specification 0-70deg C

Parameter	Value			Units	Notes
	Min	Typ	Max		
Supply voltage	1.0	1.2	1.5	V	
Supply current: transceiver		3		mA	Continuous Tx/Rx mode
Transmission distance		3		m	
TX power		-10		dBm	
Data rate			50	kbps	
Sensitivity		-97		dBm	BER 0.1%
Bandwidth		200		KHz	Binary FSK modulation
Carrier frequencies:					
ISM Europe	862		870	MHz	
ISM USA	902		928	MHz	
Prog. Ref. voltage for ISFET and amperometric sensors	10		940	mV	4 ranges, each 8bit programmable
Prog. bias current	0		155	µA	ISFET bias in 5µA steps
ECG sensor input signal bw		100		Hz	Min. set by ext. high pass filter
ADC input range		1.2		V	Differential pp

The Sensium in receive mode is a class 3 SRD receiver as defined by table 1 ETSI EN300220.

For further information: please contact Toumaz Technology Ltd

ADVANCE PRODUCT INFORMATION

Toumaz Technology Limited Suite F Centurion Court • 85 Milton Park • Abingdon • OX14 4RY •

Tel: +44 1235 438950 • Fax +44 1235 438950 www.toumaz.com